

STEAM HOSE INSTALLATION

Attach one of the steam hoses to the steam line on each end of your car as pictured in the diagram.

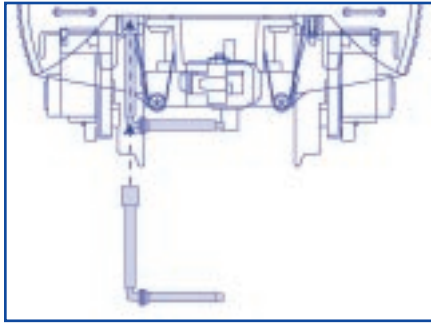

SERVICING

This product is built with pride by USA Trains and is covered by a limited warranty. (See limited warranty terms). Please follow these instructions carefully before returning:

1. Return passenger car in its original blue/red box with the proper foam inserts and then pack the original box in a proper shipping carton so it is well protected in shipment. The package must be fully insured and prepaid. USA Trains is not responsible for damage or loss during shipment.
2. Include a note explaining the problem and servicing you need performed. Be sure to include your name, street address, (NO P.O. BOXES PLEASE) City, State, Country (if outside U.S.A) and zip code along with a daytime phone number including area code. If the service is not covered by warranty, a reasonable service fee will be charged. For any passenger car to be returned outside the continental U.S.A., please include \$25.00 U.S. currency to cover return postage. Any passenger car returned to customers in the continental U.S.A. will be pre-paid by USA Trains.
3. Ship your item to:
USA TRAINS
662 CROSS STREET
MALDEN, MA. 02148

LIMITED ONE YEAR WARRANTY

This USA Trains passenger car is warranted for one year from the date of purchase against defects in material or workmanship. We will repair or replace (at our option) the defective part without charge for parts or labor within one year of the original date of purchase provided the warranty registration card has been received by USA Trains. This warranty does not cover items that have been abused or damaged by careless handling or improper operation such as a train derailment, modification or repair by non-factory technicians. Parts that "wear out" due to excessive use are also not covered under warranty. USA Trains reserves the right to determine "excessive use". Transportation costs incurred by the customer are not covered under this warranty.



EXTRUDED ALUMINUM PASSENGER CAR INSTRUCTIONS



USA TRAINS
662 CROSS STREET
MALDEN, MA 02148
USA
www.usatrains.com



Dear Customer,

Congratulations on your purchase of this highly detailed, high quality G scale extruded aluminum passenger car. You now have one of the most detailed models of a passenger car ever made. USA Trains is committed to producing the most highly detailed and authentic railroad equipment for G scale modelers.

We thank you for your continued support and hope you enjoy our products.

Happy Railroading
USA TRAINS

FEATURES

- Opening doors with separate door handles
- Authentic roof ventilators
- Interior lighting
- Fully detailed interior with seated figures
- Full underbody detail
- Rubber diaphragms
- Fold down step on vestibule ends
- Vista dome has upper seating area with painted figures
- Separately applied coupler lift bar, air hoses, and grab irons
- Observation has lighted drum head and marker lights
- Sprung die-cast metal trucks
- Metal wheels
- Additional seated figures sold separately

LIGHTING

Each passenger car is equipped with a switch to control the lights. On the bottom of the car, there is a slide switch for ON/OFF lights. The observation is equipped with a three position switch which also controls the rear lights.

All cars except observation	ALL LIGHTS ON	ALL LIGHTS OFF
	ALL LIGHTS ON	ALL LIGHTS OFF

Another feature of the lighting system is that the rear center light on the observation is red when the train is running forward and switches to white when the train operates in reverse.

INTERIOR FEATURES

Each passenger car is equipped with prototypical interiors complete with separately detailed components and hand painted figures. Additional figures can be added by removing one of the car end caps and sliding out the interior floor section. Do not remove the metal underbody floor section to avoid disturbing the electrical pickup between the trucks and the lighting system attached to the roof of the car. Additional figure sets are available from your dealer.

R310 Seated Figure Set #1
R311 Seated Figure Set #2
(Each set contains seven assorted figures).

DIE-CAST METAL KNUCKLE COUPLERS

Die-cast metal knuckle couplers are standard on each passenger car. Our engineering department has developed the most unique coupler system in model railroading in which the coupler arm is spring loaded to "cushion" the starting/stopping of the train and provide smoother operation through the curves. This unique feature does not require conversion to any other coupling system.

FOLD DOWN STEP OPERATION

For those models that feature a vestibule end, USA Trains has added a working fold down step which shows that USA Trains is committed to providing its customers the most realistic detailed product available. To operate this feature, fold down the drop step and push the vestibule door inward which allows the floor trap to raise upward.

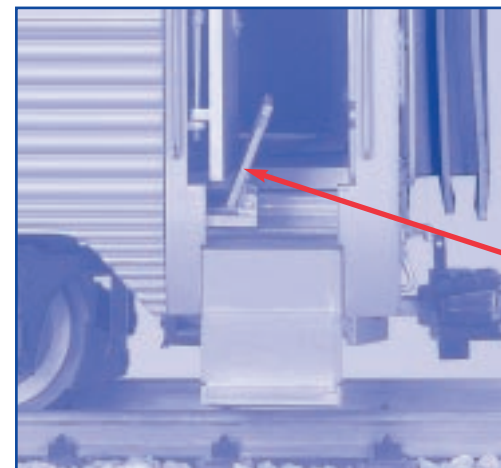

Floor Trap